

# Hydraulic Thumb Mounting Instructions

## Size 1 1/2 By 32 By 57 with 28 in. Cyl.

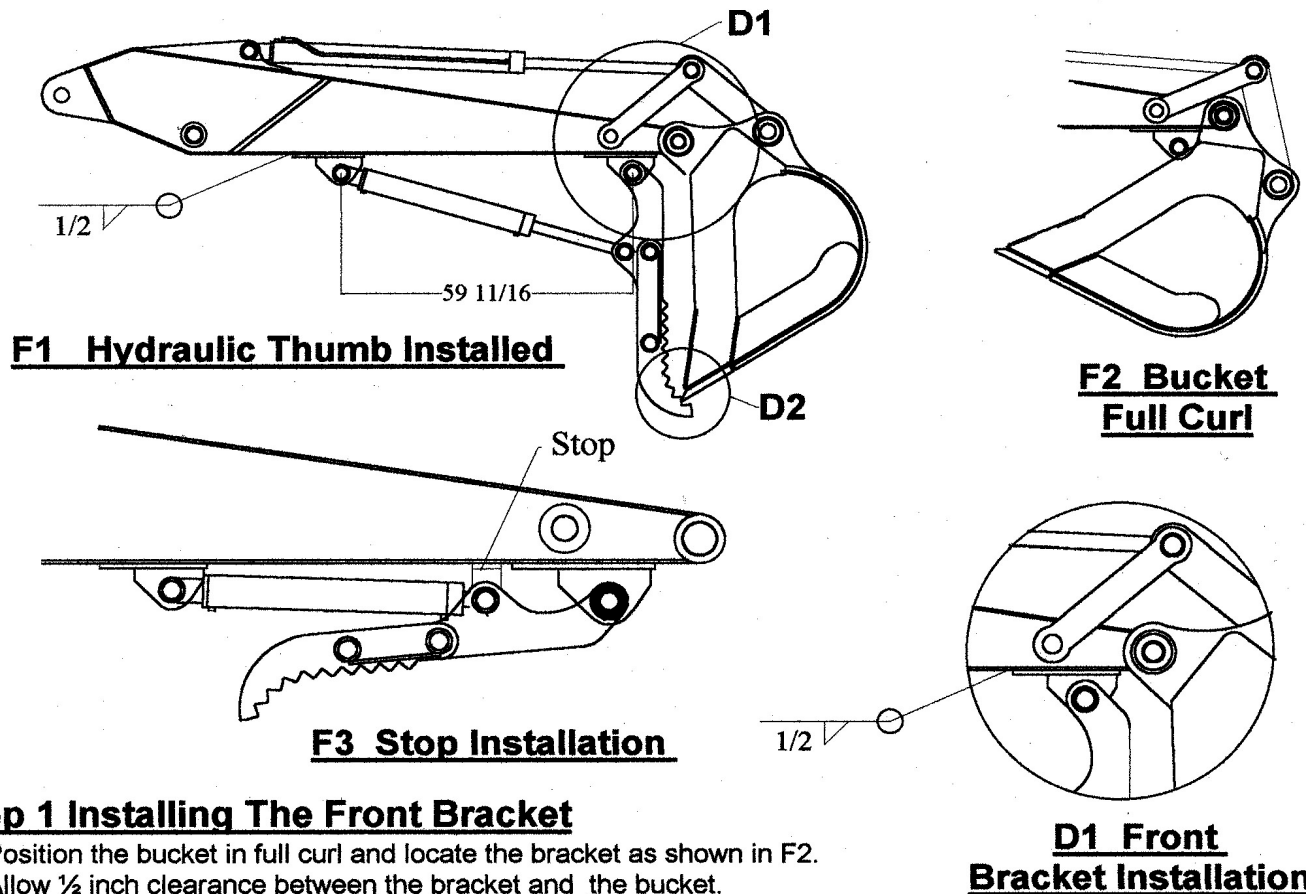

### Step 1 Installing The Front Bracket

- Position the bucket in full curl and locate the bracket as shown in F2. Allow 1/2 inch clearance between the bracket and the bucket. Then clamp or tack weld the bracket in place. The tack weld or clamp to be sufficient to hold the bracket and thumb.
- Install the thumb to the bracket.
- Check the bracket and thumb position as shown in F1. The thumb to be Position 90 degrees to the flat part of the stick as shown. Bring the bucket and thumb together as shown in figure D2. The thumb must contact the bucket cutting edge or bucket teeth. The bucket must contact the thumb only in this area. When the thumb contacts the bucket in another area the bracket position is to be moved back on the stick to remove the contact area.

### D1 Front Bracket Installation

### Step 2 Installing The Cylinder Base Bracket

- Install the cylinder bracket to the dimension shown and tack weld in place. The tack weld to be sufficient to hold the bracket, thumb and cylinder.
- Move the thumb to the minimum and maximum cylinder stroke, check that the cylinder is free and that it has no contact that would damage the cylinder.
- Finish welding the brackets to the boom using 70-18 electrode.
- The thumb is now ready for use.

### Step 2 Installing The Stop

Weld the stop to stick to march angle of thumb in the position shown.  
 Note: The stop is required to prevent the cylinder from contacting the stick and to keep the linkage from an over center condition when the distance to the back bracket is incorrect.

Note: If problems occur installing the thumb contact the manufacture to resolve the problem.

**MAX.  
PRESSURE  
2,500 psi**

\* Operating pressure MUST not exceed 2,500 psi or warranty will be void.